



6-EV-100B(100AH/3HR)

Specification

Nominal Voltage	12V	
Nominal Capacity (25°C)	3hr	100AH(1.68V/cell)
	20hr	120AH(1.75V/cell)
Dimensions	Length	330.0±2mm
	Width	173.0±2mm
	Height	212.0±2mm
	TH	220.0±2mm
Range of use temperature	discharge	-20~55°C
	charge	0~40°C
	storage	-15~50°C
Weight	32.8kg	
Standard terminal	T11	
Container material	ABS	

Battery Dimensions (mm)

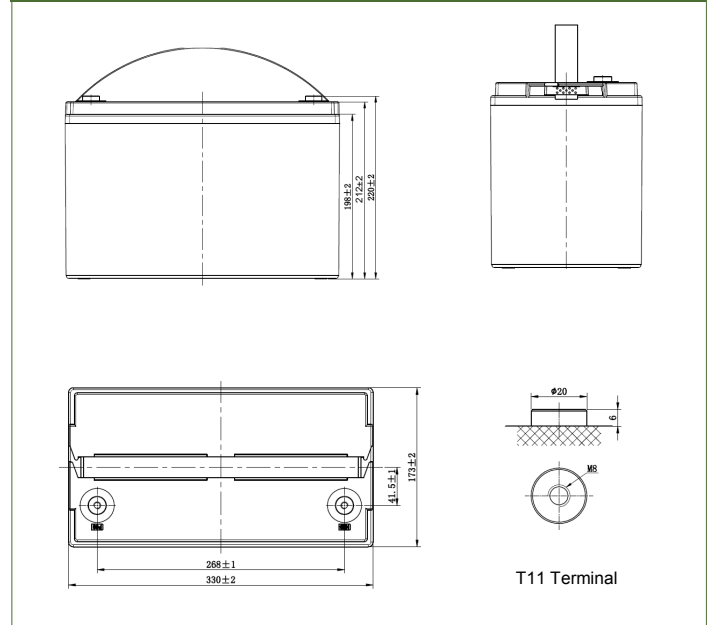

Performance Advantages

- High capacity, high energy density
- Lower self-discharge, good charge retention performance
- High conductivity terminals, good for high current discharging
- Unique valve regulated design, safe and reliable in use
- Use gel electrolyte, prevent the electrolyte stratification in use
- Special grid design and paste recipe, increase charge acceptance capability
- Lead calcium alloy used for grids, lower water loss to realize maintenance free

Charge / Discharge Tables & Graphs

Constant current charging characteristic (25°C)

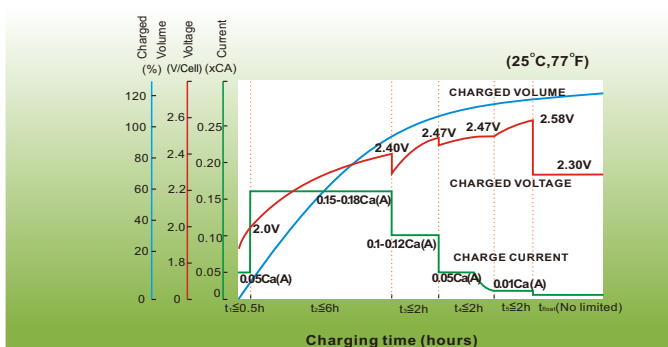

Cycle life in relation to depth of discharge

